



VISADES  
 Mauermannstrasse 2  
 5023 Salzburg  
 Tel.: 0662/871224-0  
 Fax.: 0662/871224-10  
 E-mail: office@visades.com

Device : T240TCII Version 230V AC  
 Cabinet : 460x600x150  
 Emitter : 3x80W  
 Version : Version 13

Manufacturer (company) : VISADES  
 Path : Z:\EPLAN4\P\PLANE\EN\VD0240\  
 Source : T240\_13

Changed on: 20. Mär. 2018 from (Abbreviation) ACA Number of pages 13

INTERN

EXTERN

		Date	20. Mär. 2018	T240TCII Version 230V AC 460x600x150		Title page/ Titelblatt	Version 13	=		
		Appr.	ACA							
		Contr.	Höllner							
Changes	Date	Name		Source T240_13	Date 19. Mär. 2013		3x80W		Sh 1	









5A1  
Weidmüller  
UR20-4A0-UI-16

Weidmüller  
UR20-4A0-UI-16  
4 Analog Output, U/I

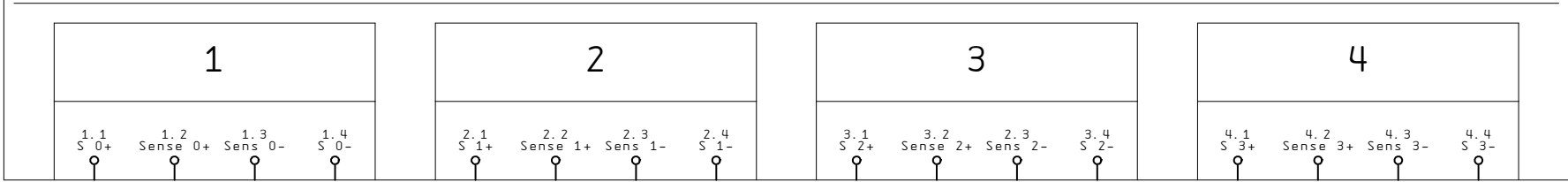

INTERN

PE

0-10V bzw. 4-20mA  
UV irradiation/  
UV Bestrahlung

0-10V bzw. 4-20mA  
Flow rate output/  
Durchfluss Istwert

0-10V bzw. 4-20mA  
Flow rate  
control/  
Durchfluss Stellwert

0-10V bzw. 4-20mA  
Reserve

EXTERN

		Datum	20. Mär. 2018	T240TCII Version 230V AC 460x600x150		Weidmüller analog output UR20-4A0-UI-16	Version 13	=		
		Bearb.	ACA					+		
		Gepr.	Höllner							
Änderung	Datum	Name		Urspr.	T240_13	DATUM	19. Mär. 2013	3x80W	s 5	



7A1  
Weidmüller  
UR20-8DI-P-2W

Weidmüller  
UR20-8DI-P-2W  
8 Digital Input, Source

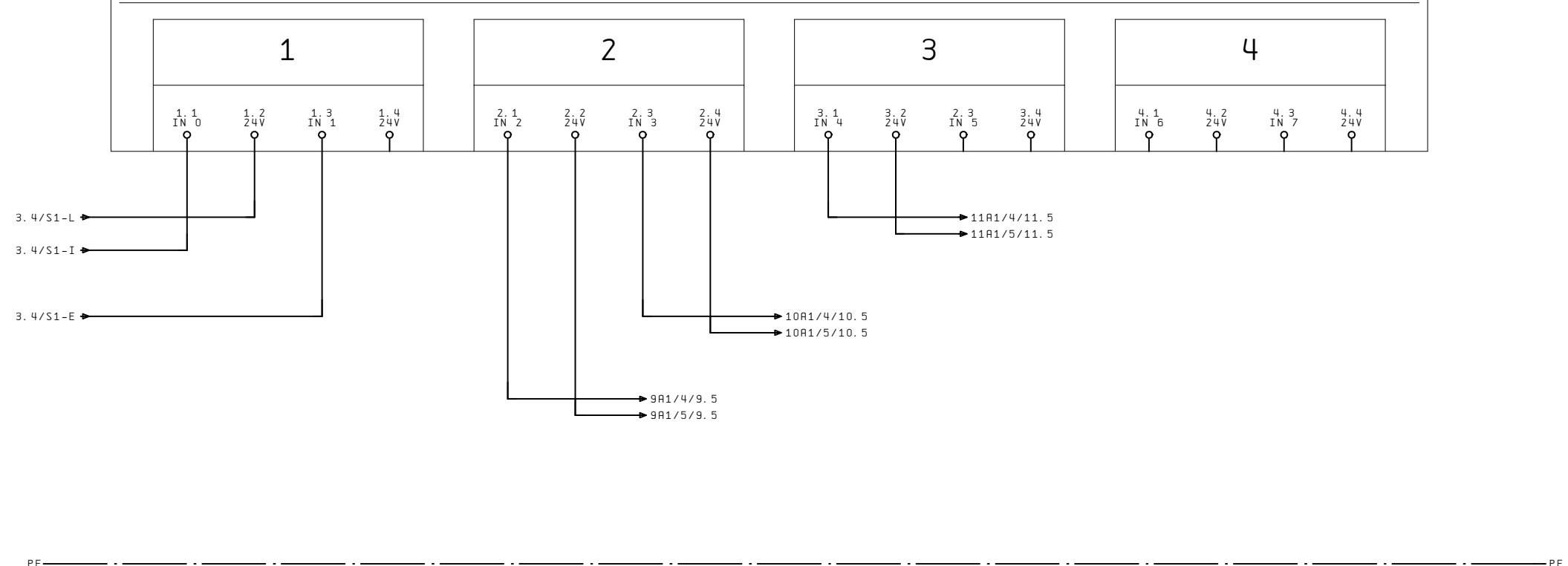

PE

1. 1/1. 2	1. 3/1. 4	2. 1/2. 2	2. 3/2. 4	3. 1/3. 2	3. 3/3. 4	4. 1/4. 2	4. 3/4. 4
ON	EXT	UV Lamp error / Lampenstörung	UV Lamp error / Lampenstörung	End pos. Main valve open/ Endlage Hauptvent. offen	End pos. Main valve close/ Endlage Hauptvent. geschl.	End pos. Flush valve open/ Endlage Spülventil offen	End pos. Flush valve close/ Endlage Spülventil geschl.

		Datum	20. Mär. 2018	T240TCII Version 230V AC 460x600x150		Weidmüller digital input UR20-4AI-UI-16	Version 13	=		
		Bearb.	ACA				+			
		Gepr.	Höllner							
Änderung	Datum	Name		Urspr.	T240_13	DATUM	19. Mär. 2013	3x80W	s	7



8A1  
Weidmüller  
UR20-4R0-CO-255

Weidmüller  
UR20-4R0-CO-255  
4 Relay Output Change Over

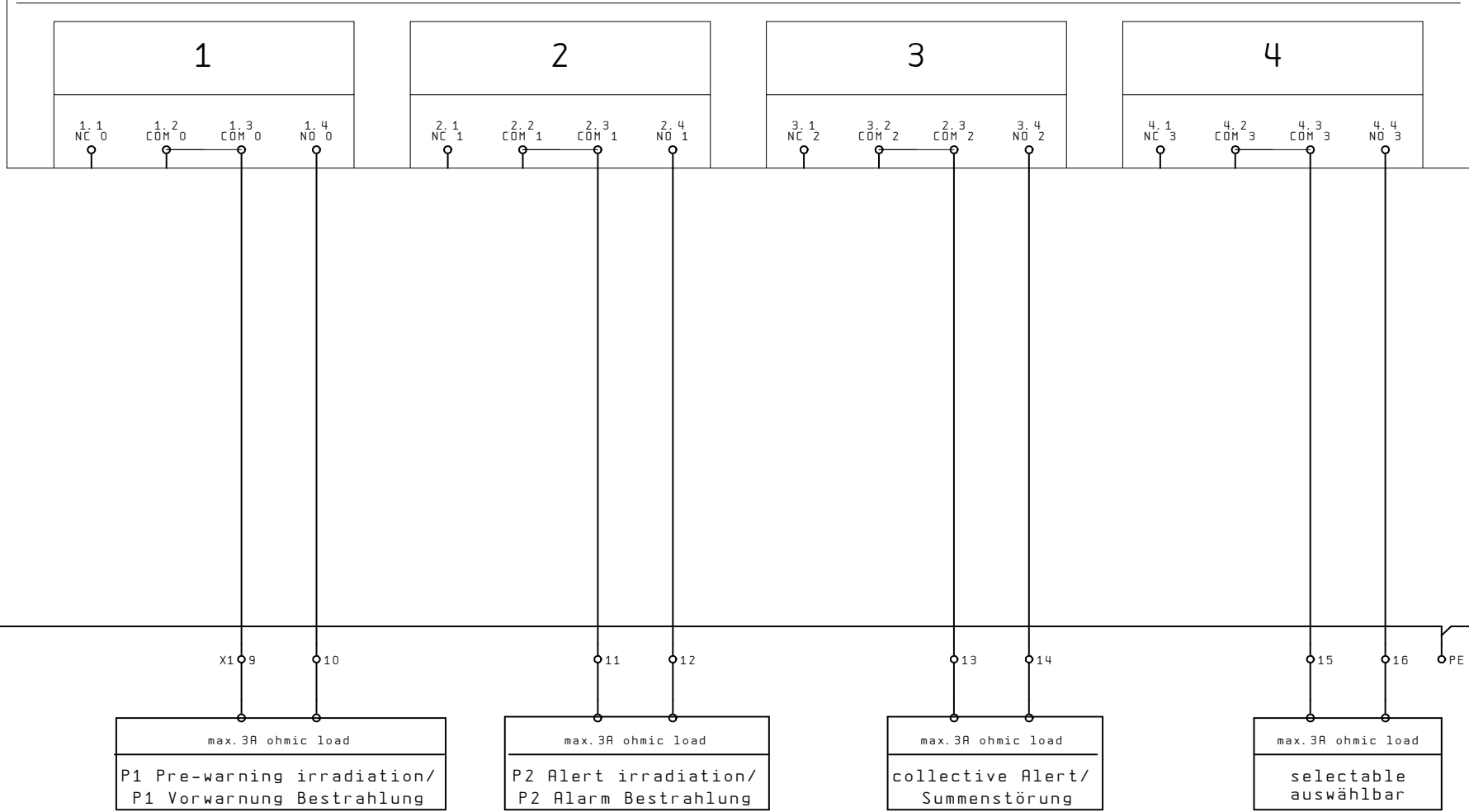

INTERN

EXTERN

7

8.1

Datum	20. Mär. 2018	T240TCII Version 230V AC 460x600x150		Weidmüller relay output UR20-4R0-CO-255	Version 13	=	
Bearb.	ACA					+	
Gepr.	Hölller						
Änderung	Datum	Name	Urspr. T240_13	DATUM 19. Mär. 2013	3x80W	S	8

8A2  
Weidmüller  
UR20-4R0-CO-255

Weidmüller  
UR20-4R0-CO-255  
4 Relay Output Change Over

INTERN

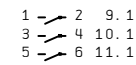
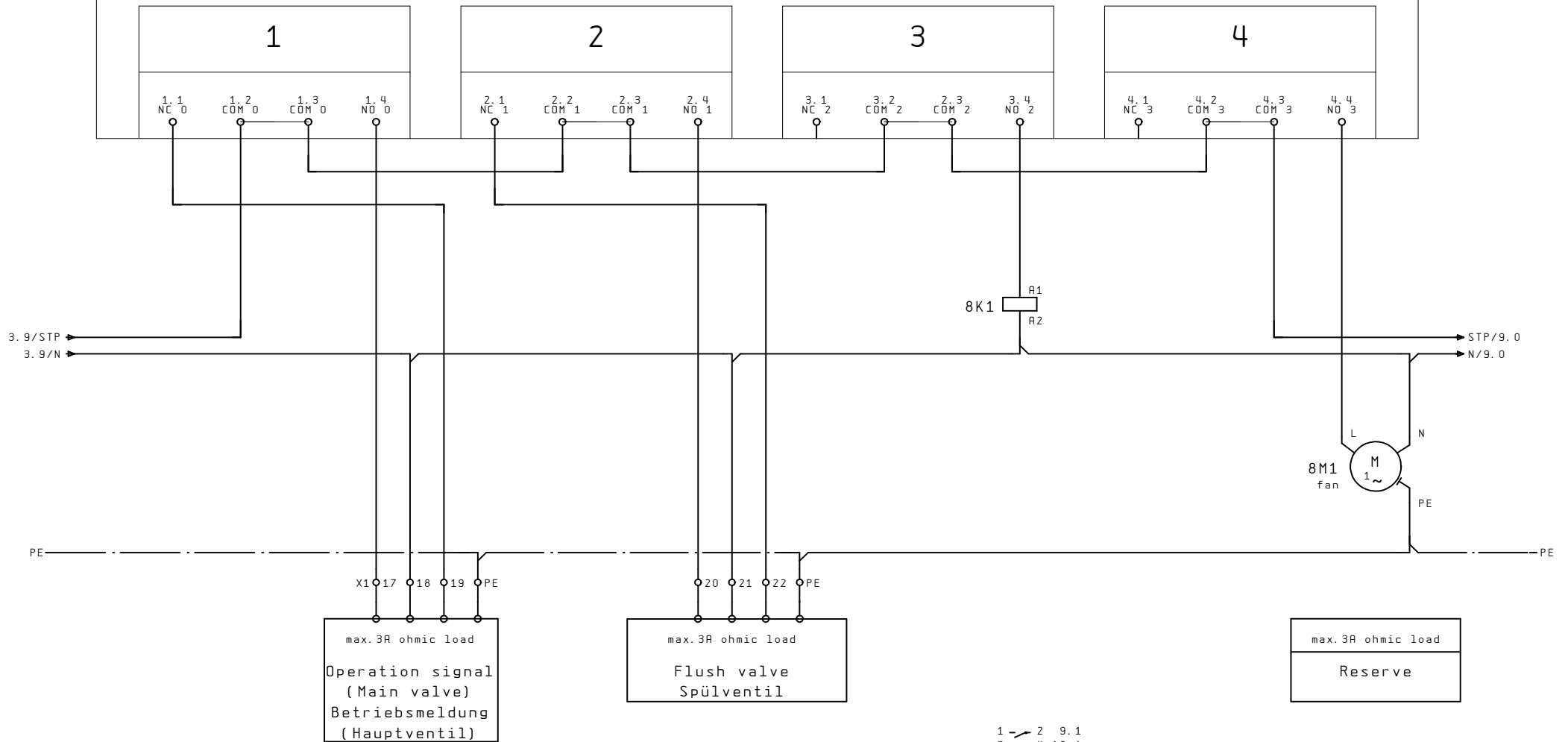

EXTERN

8

9

Datum		20. Mär. 2018		T240TCII Version 230V AC		Weidmüller relay output		Version 13		=	
Bearb.		ACA		460x600x150		UR20-4R0-CO-255		3x80W		+	
Gepr.		Höllner		Urspr. T240_13		DATUM 19. Mär. 2013		s		8.1	
Änderung		Datum		Name						11	



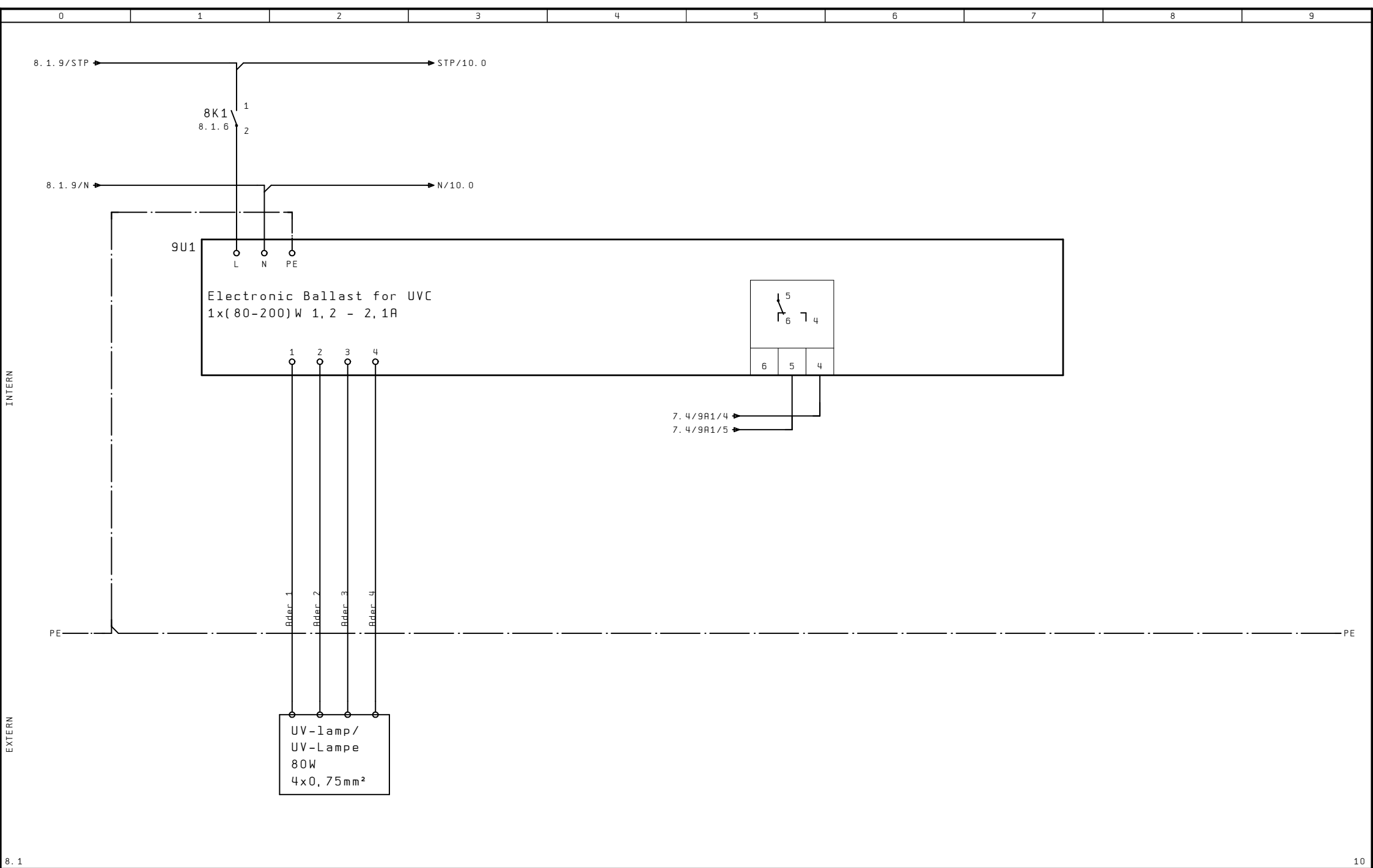

8.1		10				
Datum	20. Mär. 2018	T240TCII Version 230V AC 460x600x150	 Ballast - UV-lamp / EVG - UV-Lampe	Version 13	=	
Bearb.	ACA			3x80W	+	
Gepr.	Höllner				s	9
Änderung	Datum	Name	Urspr. T240_13	DATUM	19. Mär. 2013	11

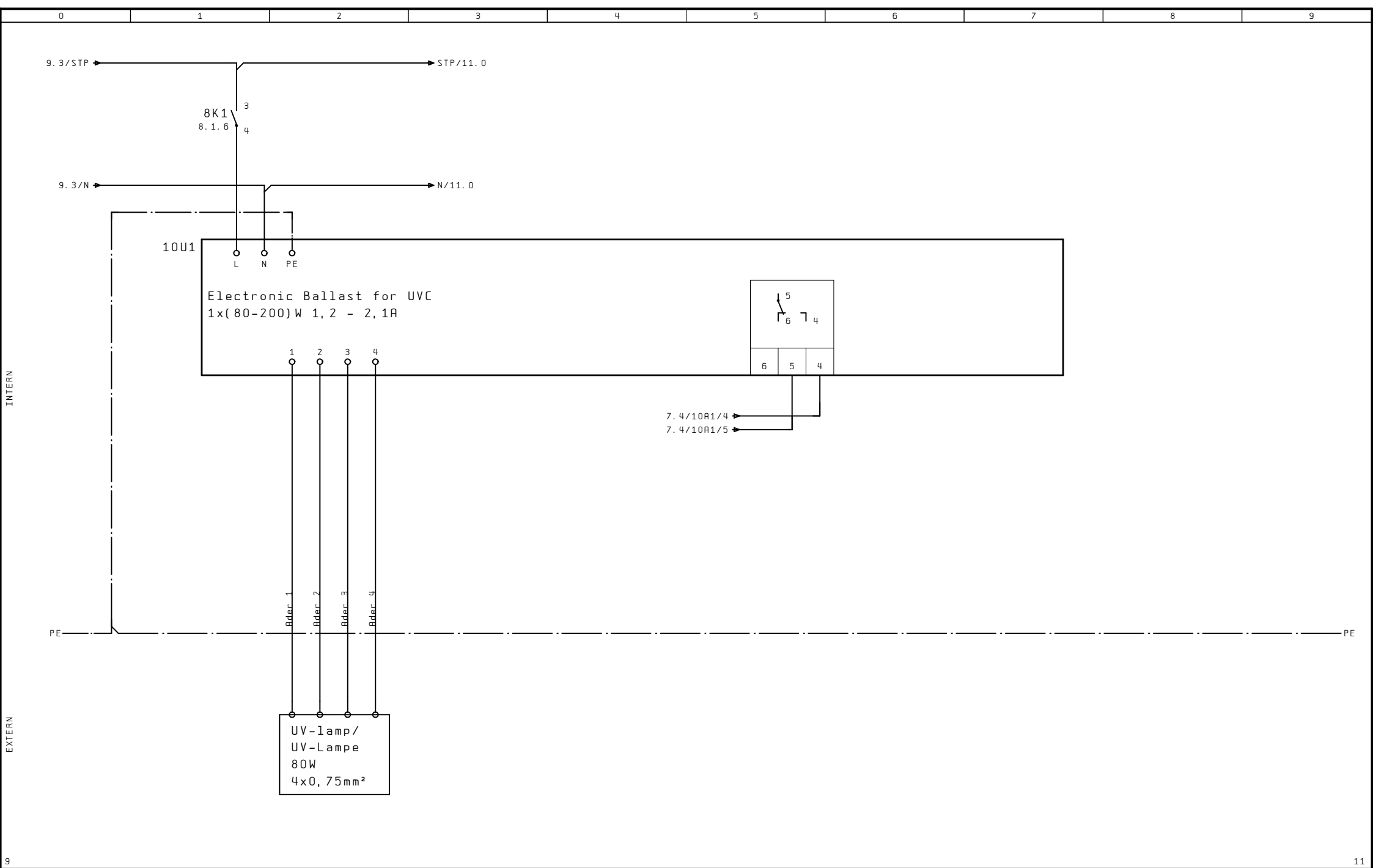

		Datum	20. Mär. 2018	T240TCII Version 230V AC 460x600x150		Ballast - UV-lamp /		Version 13	=			
		Bearb.	ACA			EVG - UV-Lampe				+		
		Gepr.	Höllner					3x80W				s
Änderung	Datum	Name		Urspr.	T240_13	DATUM	19. Mär. 2013					

